

INJECTION SYSTEM WIT-UH 300



280 ml

420 ml

825 ml



Cartridge sizes		Art. no.	Dispensing guns
280 ml	peeler	5918 504 280	p. 48
420 ml	coaxial	5918 500 420	
825 ml	side-by-side	5918 503 825	

Application references

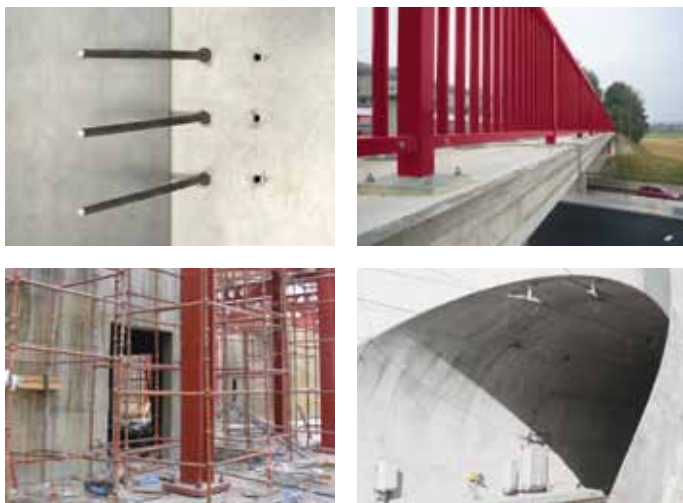

Approvals and certificates

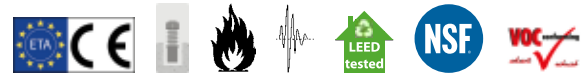

Threaded rod	Internal threaded rod	Rebar
✓	✓	✓
p. 34-36	p. 36	not supplied by Würth

Temperature of base material	Gelling – working time	Min. curing time – dry conditions ¹⁾
-5°C to -1°C	50 min	5 h
0°C to 4°C	25 min	3.5 h
5°C to 9°C	15 min	2 h
10°C to 14°C	10 min	60 min
15°C to 19°C	6 min	40 min
20°C to 29°C	3 min	30 min
30°C to 40°C	2 min	30 min

¹⁾ for wet base material the curing time must be doubled

Type of installation		
Pre-positioned	In-place	Stand-off
✓	-	✓

Installation condition		
Dry concrete	Wet concrete	Flooded drill hole
✓	✓	✓

Drilling method		
Hammer drill	Diamond drill	Hollow drill
✓	-	✓

INJECTION SYSTEM WIT-UH 300

Loads – concrete

Thread size			M8	M10	M12	M16	M20	M24	M27	M30	
Effective anchorage depth	h_{ef}	[mm]	80	90	110	125	170	210	240	270	
Non-cracked Concrete											
Tension	5.8	N_{rec}	[kN]	8.7	13.8	20.1	32.7	51.9	71.3	87.1	103.9
	8.8			13.8	20.0	27.0	32.7	51.9	71.3	87.1	103.9
	A4-70			9.9	15.7	22.5	32.7	51.9	71.3	57.4	70.2
Shear	5.8	V_{rec}	[kN]	6.3	9.9	14.5	26.9	42.0	60.5	78.7	96.2
	8.8			8.6	13.1	19.4	36.0	56.0	80.6	105.1	128.0
	A4-70			6.0	9.2	13.7	25.2	39.4	56.8	34.5	42.0
Cracked Concrete											
Tension	5.8/8.8	N_{rec}	[kN]	6.7	10.1	15.8	22.9	36.3	49.9	61.0	72.7
	A4-70			6.7	10.1	15.8	22.9	36.3	49.9	57.4	70.2
Shear	5.8	V_{rec}	[kN]	6.3	9.9	14.5	26.9	42.0	60.5	78.7	96.2
	8.8			8.6	13.1	19.4	36.0	56.0	80.6	105.1	128.0
	A4-70			6.0	9.2	13.7	25.2	39.4	56.8	34.5	42.0

¹⁾ Loads are valid for single anchors. Normal spaced reinforcement in $\geq C20/25$. Material safety factor γ_{Mk} and safety factor for action $\gamma_{Ic} = 1.4$ are included. The material safety factor depends on the failure mode.

²⁾ Loads for anchorages close to edge and/or with small spacing have to be reduced and should be calculated based on performance data given in the ETA.

Clearance-hole in fixture	d_f	[mm]	9	12	14	18	22	26	30	33
Drill depth	$h_0 = h_{ef}$	[mm]	80	90	110	125	170	210	240	270
Minimum thickness of concrete member	h_{min}	[mm]	110	120	140	161	214	266	300	340
Minimum edge distance	c_{min}	[mm]	35	40	45	50	60	65	75	80

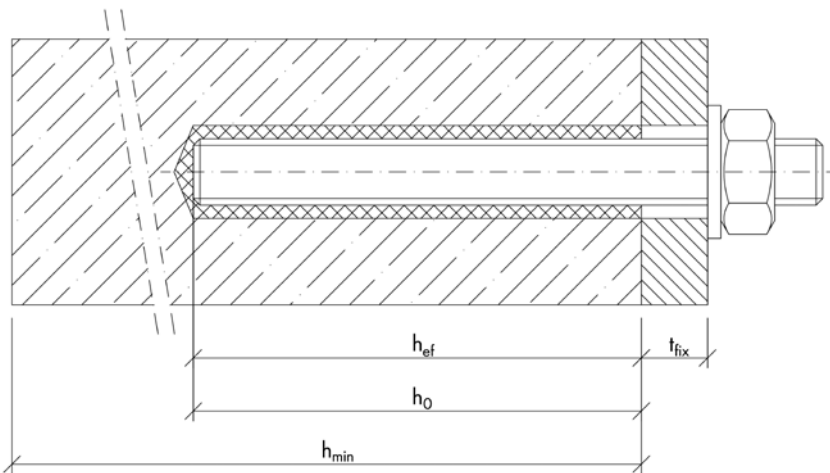

Installation Concrete

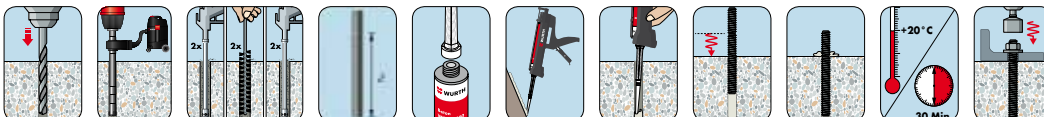

INJECTION SYSTEM WIT-UH 300

Loads – REBAR

Rebar size			Ø 8	Ø 10	Ø 12	Ø 14	Ø 16	Ø 20	Ø 25	Ø 28	Ø 32	
Effective anchorage depth	h_{ef}	[mm]	80	90	110	125	125	170	210	270	300	
Non-cracked Concrete												
Tension	B500B	N_{rec}	[kN]	13.4	18.8	27.0	32.7	32.7	51.9	71.3	103.9	121.7
Shear		V_{rec}	[kN]	6.5	10.3	14.8	20.2	26.3	41.1	64.3	80.7	105.3
Cracked Concrete												
Tension	B500B	N_{rec}	[kN]	5.3	7.4	11.8	17.0	19.4	33.1	49.9	72.7	85.2
Shear		V_{rec}	[kN]	6.5	10.3	14.8	20.2	26.3	41.1	64.3	80.7	105.3

¹⁾ Loads are valid for single anchors. Normal spaced reinforcement in $\geq C20/25$. Material safety factor γ_{Mk} and safety factor for action $\gamma_L = 1.4$ are included. The material safety factor depends on the failure mode.

²⁾ Loads for anchorages close to edge and/or with small spacing have to be reduced and should be calculated based on performance data given in the ETA.

Nominal hole diameter	d_0	[mm]	12	14	16	18	20	25	32	35	40
Effective anchorage depth	$h_{ef,min}$	[mm]	60	60	70	75	80	90	100	112	128
	$h_{ef,max}$	[mm]	160	200	240	280	320	400	500	560	640
Minimum thickness of concrete member	h_{min}	[mm]	110	120	142	161	165	220	274	340	380
Minimum spacing	s_{min}	[mm]	40	50	60	70	75	95	120	130	150
Minimum edge distance	c_{min}	[mm]	35	40	45	50	50	60	70	75	85

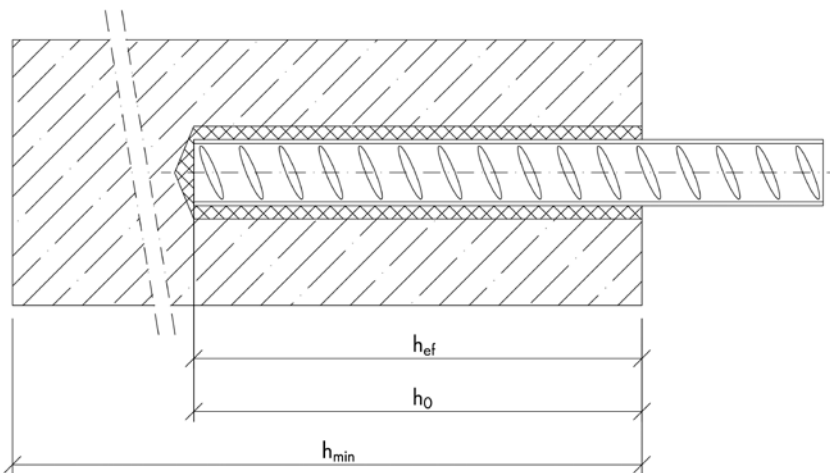

Installation REBAR

